

Series	Edge
Material	16 Gauge, Type 304 stainless steel
Installation Type	Seamless undermount workstation
Configuration	Single bowl
Finish	Soft satin brushed finish
Overall Dimensions	33 5/8" x 19 1/2" x 10 1/4"
Bowl Dimensions	31" x 15 3/4" x 9 3/4"
Drain Size	3 1/2"
Finish Available	Stainless Steel
Minimum cabinet size	36"
Template Included	No
Clips Included	No
Drain Location	Reversible
Accessories Included	Strainer, Bottom grid, Cutting board and Drying rack



ACCESSORY
Bottom Grid - GR-3022
Strainer - L-1
Drying Rack - DR1713
Cutting Board - CB1711BW

Stocked Color Options



Stainless Steel

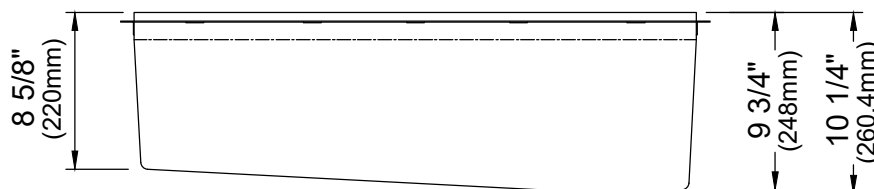
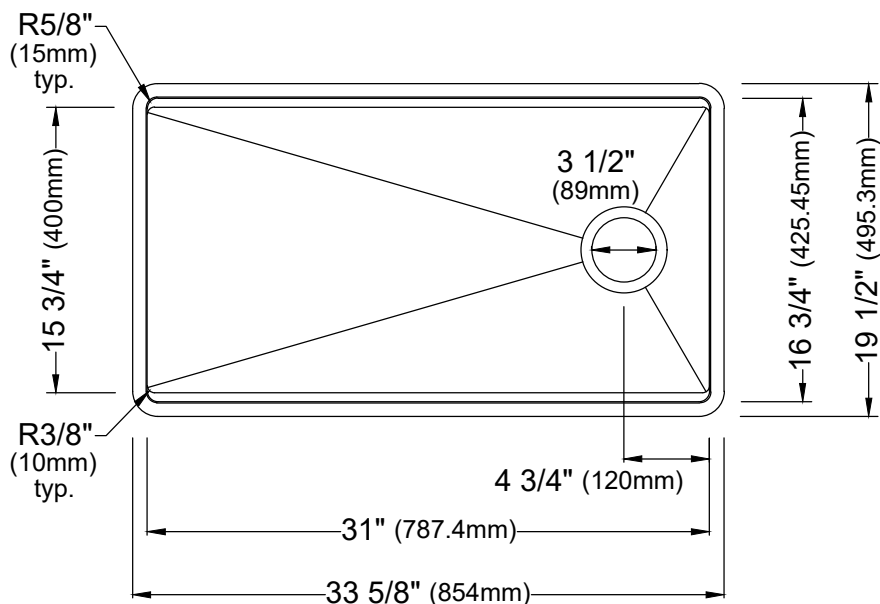

Listing and certifications:  
cUPC

Limited lifetime warranty