

Series	Fireclay Workstation
Material	Fireclay
Installation Type	Reversible Apron Front
Configuration	Single bowl
Overall Dimensions	30" x 17 5/8" x 10 1/8"
Bowl Dimensions	28 1/4" x 15 7/8" x 9 1/4"
Drain Size	3 3/4"
Finishes Available	Gloss White
Minimum cabinet size	30"
Template Included	No
Clips Included	No
Drain Locations	Center
Accessories Included	Cutting board, Strainer and Drying rack



ACCESSORY	
Cutting Board - CB1711ACR20	
Strainer - QBSGWH	
Drying Rack - DR1712BLR5	

Stocked Color Options



Gloss White

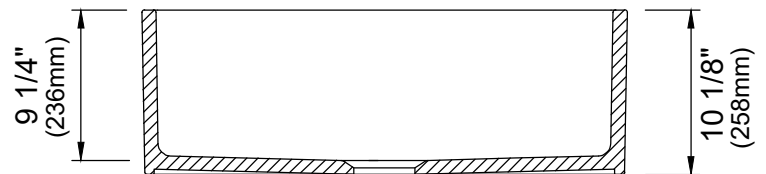
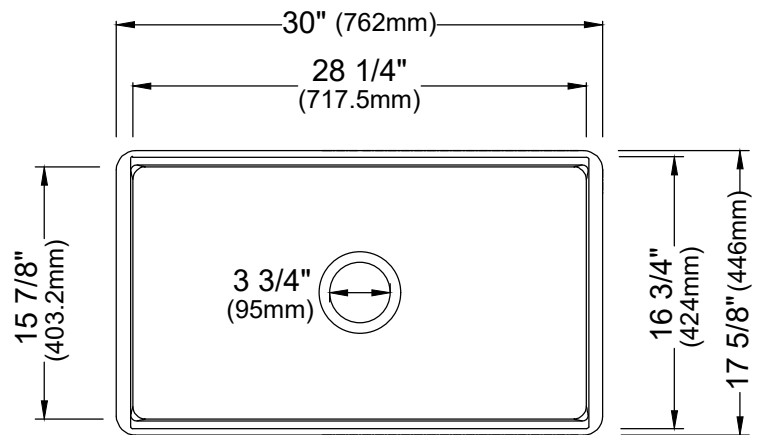

Flat Front

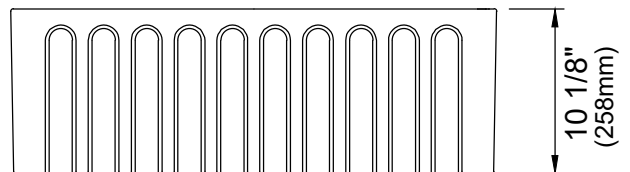

Fluted Front

Listing and certifications:
cUPC

Limited lifetime warranty

We reserve the right to update product specifications without notice. Please visit karran.com for the most current specification sheets. All dimensions are accurate to 1/4". REV 03-2026