

| | |
|----------------------|---|
| Series | Elite Workstation |
| Material | 16 Gauge, Type 304 stainless steel |
| Installation Type | Apron front |
| Configuration | Double equal bowl |
| Finish | Satin brushed finish |
| Overall Dimensions | 36" x 21" x 10" |
| Bowl Dimensions | 16 3/8" x 16" x 9 3/4" |
| Drain Size | 3 1/2" |
| Finish Available | Stainless Steel |
| Minimum cabinet size | 36" |
| Template Included | No |
| Clips Included | No |
| Drain Locations | Rear |
| Accessories Included | Strainer (x2), Bottom grid (x2), Drying rack, and Cutting board |



| ACCESSORY |
|--------------------------|
| Strainer - L-1 x2 |
| Bottom Grid - GR-3248 x2 |
| Cutting Board - CB1711SW |
| Drying Rack - DR1713 |

| MODEL | FINISH |
|------------|-----------------|
| WSA-48-PK1 | Stainless Steel |

Stocked Color Options



Stainless Steel

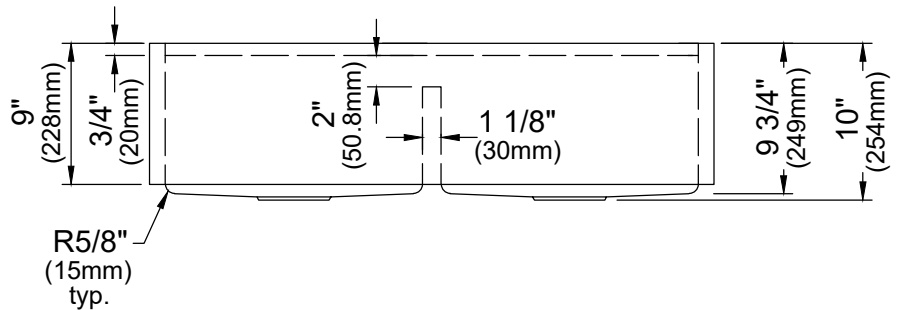
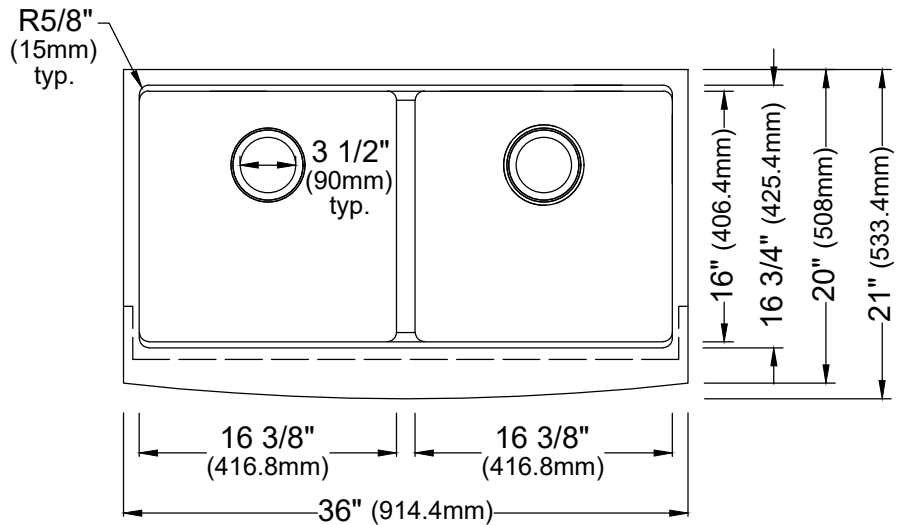

Listing and certifications:
cUPC

Limited lifetime warranty

We reserve the right to update product specifications without notice. Please visit karran.com for the most current specification sheets. All dimensions are accurate to 1/4". REV 05-2025