

Series	Elite Workstation
Material	16 Gauge, Type 304 stainless steel
Installation Type	Top mount
Configuration	Single bowl
Finish	Satin brushed finish
Overall Dimensions	33" x 22"
Bowl Dimensions	30 1/4" x 16" x 10"
Drain Size	3 5/8"
Finish Available	Stainless Steel
Minimum cabinet size	36"
Template Included	Yes
Clips Included	Yes
Drain Location	Rear
Accessories Included	Strainer, Bottom grid, Drying rack and Cutting board

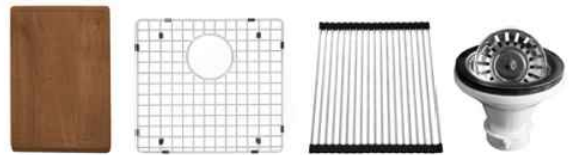

ACCESSORY	
Strainer - L-1	
Bottom Grid - GR-3232	
Cutting Board - CB1711SW	
Drying Rack - DR1713	

MODEL	FINISH
WST-23-PK1	Stainless Steel

Stocked Color Options



Stainless Steel

Listing and certifications:  
cUPC

Limited lifetime warranty

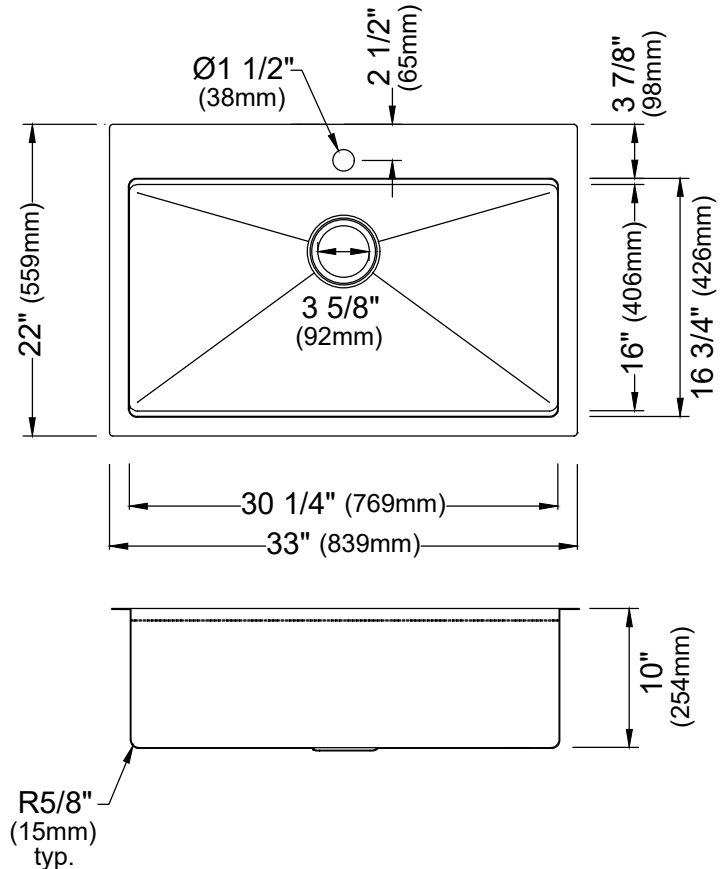

We reserve the right to update product specifications without notice. Please visit [karran.com](http://karran.com) for the most current specification sheets. All dimensions are accurate to 1/4". REV 02-2025